

THIS DRAWING IS UNPUBLISHED. RELEASED FOR PUBLICATION, 19 .
 © COPYRIGHT 19 BY AMP INCORPORATED. ALL RIGHTS RESERVED.

LOC		DIST		REVISIONS			
P	LTR	DESCRIPTION		DATE	DWN	APVD	
G	14	G	REL PER 0G3A-0525-01	27SEP01	JR	MS	

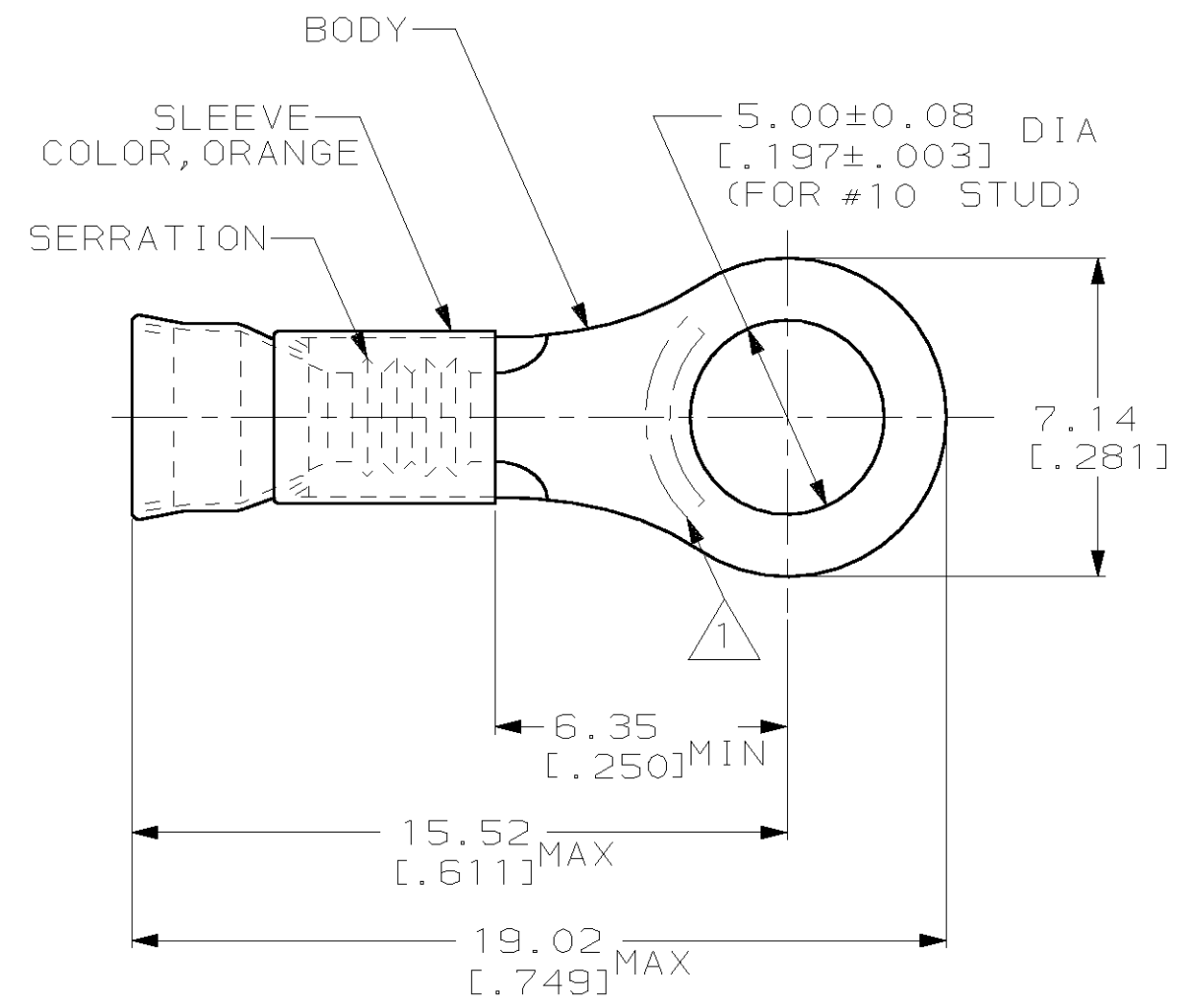

- 1. STAMP AMP 22-18 APPROX AS SHOWN
22-16 TERMINALS ARE STAMPED 22-18 IN ACCORDANCE WITH MILITARY SPEC MIL-T-7928 COMMERCIAL WIRE RANGE IS 22-16
- 2. WIRE INSUL DIA, 2.67-3.56 [.105-.140]
- 3. TONGUE MATL THK, 0.79±0.05 [.031±.002]
- 4. PREPRODUCTION - FASR REQ

QTY	PACKAGE TYPE	PART NO
5000	ON TAPE, REEL	2-321894-1
1000	LOOSE PIECE	321894

AMP INCORPORATED
 CUSTOMER SERVICE SYSTEM

FOR ADDITIONAL PRODUCT INFORMATION OR COPIES OF DRAWINGS AND TECHNICAL DOCUMENTS: PRODUCT INFORMATION CENTER 1-800-522-6752

FOR APPLICATION TOOLING INFORMATION: TOOLING ASSISTANCE CENTER 1-800-722-1111

FOR ORDER ENTRY: 1-800-526-5142

MAX RECOMMENDED OPERATING TEMPERATURE:
 649°C [1200°F]

VOLTAGE RATING:
 -

CIRCULAR MIL AREA:
 0.26mm²-1.65mm² [509-3260]

STRANDED WIRE

THIS DRAWING IS A CONTROLLED DOCUMENT FOR AMP INCORPORATED. IT IS SUBJECT TO CHANGE AND THE CONTROLLING ENGINEERING ORGANIZATION SHOULD BE CONTACTED FOR THE LATEST REVISION.

DIMENSIONS:	TOLERANCES UNLESS OTHERWISE SPECIFIED:
mm [in]	
	0 PLC ±-
	1 PLC ±-
	2 PLC ±0.20 [.008]
	3 PLC ±-
4 PLC ANGLES ±-	

MATERIAL: BODY, NI PER ASTM B162; SLEEVE, NI SIL PER ASTM B122

FINISH: -

DWN L OLMEDA 100CT94	AMP Incorporated Harrisburg, PA 17105-3608
CHK M ELLIS 100CT94	
APVD S BORTNER 100CT94	
PRODUCT SPEC -	
APPLICATION SPEC -	NAME TERMINAL, RING TONGUE, STRATOTHERM, DIAMOND GRIP, WIRE SIZE, 22-16 AWG
WEIGHT -	SIZE A3 CAGE CODE 00779 DRAWING NO C-321894
CUSTOMER DRAWING	SCALE 6:1 SHEET 1 OF 1 REV G